

# NABS Factsheet

## Getting Started with Bluebirds

Over the years, land has been cleared for housing and commercial developments, highways and agriculture, and many old trees have been cut down. Wooden fence posts that provided nesting cavities have been replaced with metal posts. With modernization, the supply of natural nesting cavities for bluebirds and other native cavity nesters has been greatly reduced.



Dave Kinnear

Habitat loss was compounded by the introduction into North America of two imported species—the European Starling and the House Sparrow (not to be confused with sparrows that are native to North America, such as the Song Sparrow, Tree Sparrow, etc.). Both starlings and House Sparrows are cavity nesters. Both are very aggressive. House Sparrows are small enough to enter any hole that a bluebird can, and will chase away or kill bluebirds. Starlings can be excluded from entering nestboxes boxes by using the correct size entrance hole, but will out-compete bluebirds for woodpecker holes and other natural nesting cavities.

During the summer, bluebirds feed mainly on insects. In the winter, they depend on wild berries. However, the supply of wild berries has decreased over the years. The few that remain are often quickly stripped by large flocks of starlings.

Even though bluebird populations have decreased, their future can still be promising. The most important step we can take to help bring back the bluebird is to provide nesting sites by setting out a bluebird nestbox or starting a bluebird trail. A bluebird trail is a series of bluebird boxes placed along a prescribed route. In areas where nestboxes have been put up in suitable habitat, bluebird populations are increasing. Bluebirding is a great hands-on environmental project that people of all ages can enjoy. By following the instructions below, chances are good that you will be able to attract and enjoy bluebirds.

### THE BLUEBIRD NESTBOX

- A good bluebird box should be well ventilated, watertight, and have drainage holes. It should be easy to open, monitor, and easy to clean.
- Solid, untreated wood is an ideal material, although exterior grade plywood can be used. The **outside** of boxes can be painted or stained if a light color is used.
- A bluebird box should not have a perch. Predatory House Sparrows and House Wrens are attracted to perches.
- Nestboxes for Eastern Bluebirds should have a round entrance hole measuring  $1\frac{1}{2}$ " to  $1\frac{9}{16}$ " in diameter, or a  $1\frac{3}{8}$ " x  $2\frac{1}{4}$ " vertical oval hole, or a  $1\frac{1}{8}$ " to  $1\frac{3}{16}$ " horizontal slot entrance. Western and Mountain Bluebirds use a  $1\frac{9}{16}$ " round opening or  $1\frac{3}{16}$ " slot entrance. Because there are no undesirable species that can access  $1\frac{9}{16}$ " holes that cannot also access  $1\frac{1}{2}$ " holes, some monitors in Eastern Bluebird territory use  $1\frac{9}{16}$ " holes.
- Although bluebirds seem to prefer oval holes, smaller European Starlings may be able to enter them, especially if they are not **exactly**  $1\frac{3}{8}$ " x  $2\frac{1}{4}$ ". Nestboxes that are on the small to moderate side reduce the possibility of starling use.
- Bluebird nestboxes are available from NABS and most bluebird organizations, or from commercial sources. Plans for building nestboxes are also available. Please see the NABS factsheet, [Nestbox Specifications](#) (also online at [www.nabluebirdsociety.org/bluebirdfacts.htm](http://www.nabluebirdsociety.org/bluebirdfacts.htm)).

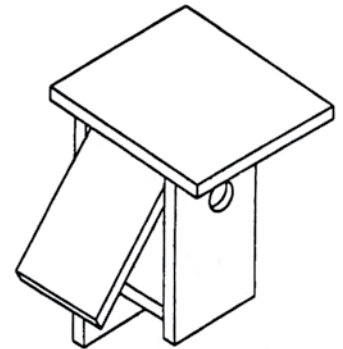

## MOUNTING THE BLUEBIRD BOX

- Smooth round pipe is probably the best and simplest mounting system to use — ½" or 1" electrical conduit works well, but any smooth scrap round pipe will also work. A fencepost driver, available at hardware stores, is an excellent tool for driving conduit into the ground.
- Avoid mounting bluebird boxes on a fence line or on trees where climbing mammals or snakes are present.
- Periodically coating the pole with wax or food-grade grease will help to keep climbing predators away from the box.
- Hardware cloth, or a wobbling stovepipe (Kingston) or PVC baffle placed on the pole directly underneath the box helps prevent access by climbing predators, including snakes (see examples at right).

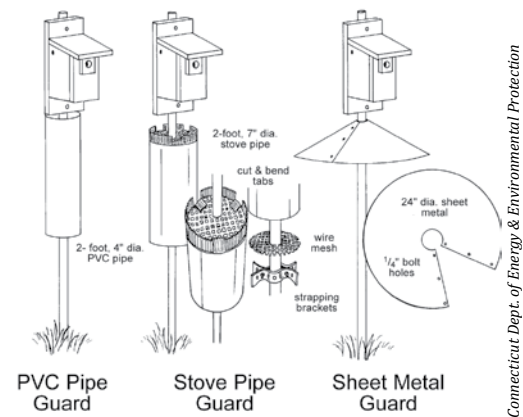

Refer to the NABS factsheet on [Predator Control](http://www.nabluebirdsociety.org/bluebirdfacts.htm) ([www.nabluebirdsociety.org/bluebirdfacts.htm](http://www.nabluebirdsociety.org/bluebirdfacts.htm)) for more information.

## SETTING UP A BLUEBIRD TRAIL

- Habitat is the key factor to consider when setting up a bluebird trail. Open rural country with scattered trees and low or sparse ground cover is best. Suitable habitat should include a fence line, wires, tree branches, or other sites where bluebirds can perch to search for food. If bluebirds do not like the habitat, they probably will not use your nestboxes.
- Open pastureland, parks away from human traffic, and mowed areas such as cemeteries and golf courses are all good locations for a bluebird trail.
- Avoid areas of heavy pesticide use.
- Mount nestboxes at least 50–200 feet away from brushy and heavily wooded areas—this is the habitat of the House Wren, a native species that may destroy bluebird eggs and/or compete with bluebirds for nestboxes.
- Avoid areas where the House Sparrow is abundant, such as farmsteads and feedlots, or where people feed cheap birdseed containing millet and cracked corn. House Sparrows are vicious competitors. People who successfully raise bluebirds (and other native secondary cavity nesters) in House Sparrow territory generally trap and euthanize House Sparrows that invade nestboxes, but this may be too late to save young or adult bluebirds from House Sparrow attack.
- For convenience, mount nestboxes so the entrance hole is approximately five feet (eye level) above the ground. Alternatively, a large hook can be installed on nestboxes, which can then be hung in trees by using a long pole. The Southern California Bluebird Club has had good success with this method; they are an excellent source of information.
- Face the nestbox away from prevailing winds, and if possible, face it toward a tree or shrub that is within 100 feet of the box to provide a landing spot for the young bluebirds when they first leave the box. This will keep them off the ground, away from predators.
- Nesting density for all three species of bluebirds is dependent on many factors. These factors include population density, habitat suitability, food supply, individual tolerance levels, visibility between boxes, the number of cavities available, weather, and the level of competition from other species (especially Tree Swallows or, in the West, Violet-green Swallows). It is therefore difficult to predetermine the optimal spacing for any given area. The



following distances are given as general guidelines only; **contact your local bluebird affiliate organization** to find out what they recommend, and experiment by adjusting the distances between your own boxes until you have established ideal spacing for your particular location. In many cases, bluebirds have been observed nesting closer than the distances recommended. However, it is better to start a bluebird trail with boxes placed too far apart than too close together.

Western Bluebirds — 100 yards apart — 200-300 yards may be better

Eastern Bluebirds — 100 yards minimum — 125 to 150 yards apart may be better

Mountain Bluebirds — 200 to 300 yards apart

- Nestboxes can be mounted in pairs in areas where Tree Swallows are abundant. When paired, boxes should be mounted 5 to 15 feet apart. This provides nesting sites for both species and helps to prevent competition between them. Different species of native birds usually do not mind nesting close to each other.
- Although bluebirds generally prefer rural areas, they will nest in golf courses, cemeteries, and along the outer edges of cities or in small towns.

### MONITORING A BLUEBIRD TRAIL

Note: For more detailed information on this topic, refer to the NABS factsheet **Monitoring Bluebird Nestboxes** (available online at [www.nabluebirdsociety.org/bluebirdfacts.htm](http://www.nabluebirdsociety.org/bluebirdfacts.htm)).

Please do not put up a bluebird nestbox if you do not plan to monitor it. Check your bluebird boxes at least once or twice a week during the nesting season, until chicks are close to fledging.

Do not open the box after nestlings are 12–13 days old. Doing so could result in the nestlings leaving the box before they are able to fly, greatly reducing their chance of survival.

Do not allow House Sparrows to use nestboxes. House Sparrows are a non-native, nuisance species that will kill adult and nestling bluebirds and destroy eggs. Like starlings, they are not protected by federal law. For more information, see the NABS factsheet **House Sparrow Control** ([www.nabluebirdsociety.org/bluebirdfacts.htm](http://www.nabluebirdsociety.org/bluebirdfacts.htm)).

Any other native bird that uses your nestbox (e.g., chickadees, titmice, nuthatches, Tree or Violet-green Swallows) should be welcomed, as these small cavity nesters need help, too. It is also illegal to disturb an active nest of a native bird without a permit.

Bluebirds usually begin to nest in late March or early April, depending on weather conditions. In southern states, where bluebirds reside year round, nesting may occur even earlier.

Have your bluebird boxes in place by early spring when the bluebirds are looking for nesting sites. Boxes may also be put up later in the nesting season. In areas where bluebirds are present year round, they may use nestboxes for roosting on cold nights.

Bluebirds usually have two broods per season, but three or even four broods are possible, especially in warmer climates.

Learn to recognize a bluebird nest. It is a cup-shaped nest that is usually made entirely of woven grass or pine needles.



Dave Kinnerer



Virginia State Parks



Bluebirds usually lay 4 or 5 light blue eggs, but may lay as many as 6 or 7. About 4–5% of bluebirds lay white eggs.

The typical incubation period for bluebird eggs is 12–14 days. A rule of thumb for Eastern Bluebirds is that eggs will hatch 17 days after the first egg is laid.

Nestlings remain in the nest 17–21 days before they fledge.

Remove bluebird nests and those of other birds as soon as the young birds have fledged. Brushing out the box and scraping off the guano is all that is necessary.

Keep records of the activity on your bluebird trail. This information is valuable to organizations like the Cornell Laboratory of Ornithology, which compiles data on bluebird populations in North America. Many NABS Affiliates also keep records of trail activity.

Don't be discouraged if your nestboxes are not used right away. If bluebirds are not common in your area, it may take them a few seasons to find your new box. Bluebirds generally return to the same area each year. Bluebird trails have been an extremely effective method of reestablishing the bluebird populations across North America.



Flickr Creative Commons/mctheriot

Revised May 2012

*The North American Bluebird Society, Inc. is a non-profit education, conservation, and research organization that promotes the recovery of bluebirds and other native cavity-nesting bird species in North America.*

[www.nabluebirdsociety.org](http://www.nabluebirdsociety.org)

