

NABS Factsheet

Predator Control

Putting up a nestbox is a responsibility that should not be taken lightly. When you put up a box, a commitment is made to provide as safe a place as possible for bluebirds to raise their young. If this commitment is taken seriously, both you and the bluebirds will be rewarded.

Bluebirding is a great outdoor activity but, from time to time, problems will arise on your trail. Common problems include weather, attacks by House Sparrows, House Wrens, and climbing predators such as raccoons, cats, and snakes. We cannot control the weather. House Sparrows and House Wrens are a challenge. But losses due to mice and climbing predators can and should be controlled.

Proper box placement can be a factor in raccoon predation. Boxes placed in pastureland are less likely to attract raccoons, compared to boxes placed near a wooded area with water nearby.

There are two definite lines of defense against raccoons. The best way is to keep the raccoon off the box. The second is to prevent the raccoon from reaching into the box if it gets in a position to try. This factsheet summarizes some methods used by experienced bluebirders. Note that similar preventive methods apply to snakes and cats.

Snakes can climb smooth poles, even greased ones. Snakes are more of a common problem in the southern states but some snake problems may occur all across North America. The stovepipe and cone guards shown below are effective for snake control; the larger the diameter of the guard, the better its effectiveness. A 24-inch piece of hardware cloth placed directly underneath the box also helps. A Noel guard attached to the entrance of a nestbox can reduce the reach of predators trying to remove nestbox contents.

Both domestic and feral cats pose a threat to bluebirds. The guards mentioned below may deter a cat, but some can jump as high as 6 feet. If cats are in your area, place your box as high as possible on a smooth pole. A large overhanging roof can also be a good deterrent.

Please do not let the possibility of predation problems discourage you from putting up a bluebird box. Mounting your box on a smooth round pipe will greatly reduce the chance of a loss to a predator. Any other preventative measures taken will provide added protection.



Jim Williams



Wikimedia/raccoon: Bernard Landgraf / black rat snake: Carly Lesser / cat: Jennifer Barnard



MOUNTING SYSTEMS

The easiest way to mount a bluebird box would be to nail it to a wooden fence post or to a tree. Although this may work in certain parts of North America where there are few raccoons or snakes, it is generally not recommended. Mice, chipmunks, and squirrels in those areas may also raid nests. Raccoons climb trees and walk fence lines where they may eventually find your box. Taking the time to properly mount your boxes may take care of your raccoon problems.

A smooth clean pipe is the best mounting system to use. A 10-foot piece of ½-inch or 1-inch electrical conduit pipe can be purchased for a reasonable price. It will then need to be cut down to a length of approximately 8 feet, to place 2 feet of pipe in the ground and six feet of pipe above. Electrical conduit is zinc plated and will keep its slick surface for many years. Other heavy round pipe will also work well. Scrap pipe found at construction sites and salvage yards can also be used. An excellent source of pipe is from overhead garage door companies. In their scrap piles from discarded doors, you will find either an 8 foot or 16 foot piece of 1 inch pipe. Most businesses will be glad to give them to you.

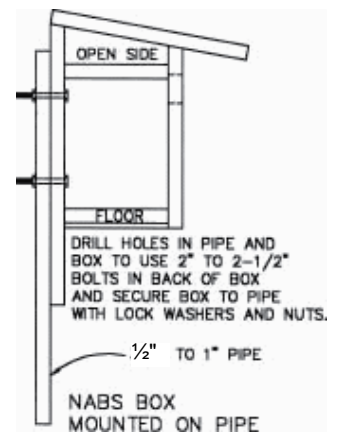

If they are rusty, sand them smooth. Flattening the bottom of the pipe with a heavy hammer will help stabilize the pipe and keep it from turning. For putting the pipe in the ground, a fencepost driver or 35 lb. digging bar is recommended over a heavy hammer. There are several easy ways to mount a nestbox to the pole:

- Pre-drill two 5/16-inch holes through both the conduit or pipe and the back of the box. Use 1/4-inch bolts to anchor the box to the pole. The drilling can be done before placement in the field.
- Wrap two pieces of pipe strap around the pole and screw it into the back of the box on either side of the pole. Secure another small piece of pipe strap to the back top, and bend it down into the pole to keep the box from turning.
- Place two electrical conduit hangers around the pole and screw them into the box.
- Drill one hole at the top of the nestbox and pole. Use a U-clamp at the bottom of the box to secure it to the pole and keep it from swinging.

A method that works well for mounting lightweight boxes (like PVC boxes) is to use a 5-foot piece of 1/2-inch electrical conduit slipped over a 5-foot piece of rebar driven approximately 2 feet into the ground. A conduit connector (with a longer bottom screw) at the base keeps the conduit from turning.

A nestbox may also be mounted on PVC pipe. Slip a 4-inch PVC pipe over a metal T-post, which makes a secure system when your box is located in a pasture with cattle. Mount your box high enough on the PVC so that cattle will not have any sharp corners to rub against.

Downspouts can also be used. A 10-foot length of downspout can be cut into three 3-foot 4-inch pieces, which is attached to the back of the box. This can then be slipped over a metal T-post.

If possible, don't install your boxes within 10 feet of a tree or any other secure object from which a predator or other pest (raccoon, cat, squirrel, etc.) can jump.

By using the above methods, together with predator guards described in the next section, predation by climbing predators will be greatly minimized.

For added protection, rub the pole down with steel wool and apply a layer of Carnuba car wax or silicone spray.

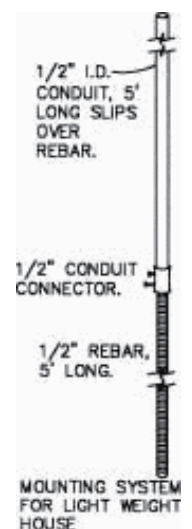

POLE GUARDS

Some bluebirders prefer using a guard on the pole or post on which their nestbox is mounted. Wide-diameter guards are better than narrow. Guard designs that have proved to be successful include the Kingston Stove Pipe guard, the Zeleny Cone, and the PVC Baffle:

Kingston Stove Pipe

This guard, designed by Ron Kingston, deters snakes, raccoons, opossums, and cats.

Material List:

- Galvanized stove or vent pipe, 8-inch diameter x 24 inches long
- 1/2-inch hardware cloth (flexible wire mesh)
- 2 hanger iron straps, 7 inches long
- 2 No. 8 B32 x 3/4-inch machine screws and nuts

Instructions:

1. Use tin snips (offset are best) to cut a hardware cloth circle that is 2" wider than the stovepipe. Be careful of cuts and scrapes.
2. Cut a small hole or "X" in the middle of the circle (the diameter of your pipe - usually 1/2 to 1 inch.)
3. Put the circle over the top of the stovepipe. Then bend the edges down one inch all around so it fits tightly INSIDE the stovepipe.
4. Cut three tabs in the top of the stovepipe. Bend these over the hardware cloth.
5. Bolt the two strips of hanger iron (or a hose clamp) securely on either side of the mounting pipe, and bend them to support the hardware cloth. Duct tape wrapped around the pole helps hold the hanger iron in place. Alternatively, drill a hole through the pipe, push a threaded rod or screw through it, and hang the guard on it.
6. Double-check that there are no gaps that would allow snakes to squeeze through. You can take a slotted screwdriver and use it to pry the hardware cloth up against the stovepipe sides.
7. Slip the assembled baffle over the pole until it rests on the hanger iron bracket. The top of the baffle needs to be at least four feet off the ground. The baffle should wobble a little to discourage climbing predators.

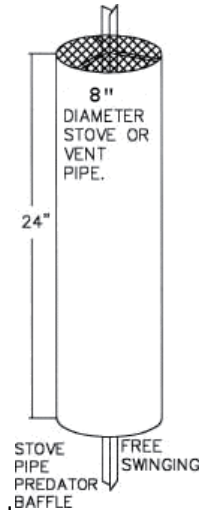

Zeleny Cone

Note that the edges of the cone may be quite sharp, posing a hazard to children and interfering with monitoring.

Material List:

- 3-foot diameter circle of 24- or 26-gauge galvanized sheet metal
- 1/4-inch round head stove bolts
- 2 hanger iron straps
- Disc blades also work well and can easily be found at farm auctions.

Instructions:

1. Cut a 3 foot square piece of 24 or 26 gauge galvanized sheet metal.
2. Cut out circle.
 - Your circle will be 18" from the center of the circle to the edge (i.e., 36" in diameter when flat; when formed into a cone the finished diameter will be less).
 - You can make a homemade compass to scribe the metal, using a stick of wood with two sharp nails placed 18" part, or a piece of string and a marker.
3. To form a cone, you will need to cut an open triangle that measures 9" on the bottom.
4. You can either attach the cone to the post using angled wooden blocks (see Step 7) or metal tabs from the center hole that bend over and are nailed to the pole. Make the tabs about 1.5" wide, and bend them up to nail to pole/box. The blocks might be better as they will make the baffle wobbly, which is harder to climb.
5. Include a hole (with tabs if desired) in the center that will be big enough for your post:
 - 5" hole fits 4" diameter post
 - 6" hole fits 5" diameter post
 - 7" hole fits 5.5 - 6.5" diameter post
 - 7.25" hole fits 6" diameter post

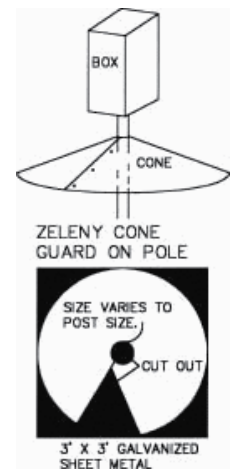

6. If you have a metal/T-post, or small wood post, you can make a V-cut instead in the center with three small tabs that can be used to attach the cone the bottom of a 2x4 on the back of the nestbox.
7. If you don't make pre-cut metal tabs you can make angled wood blocks to nail the guard in place. The ends should be angled to fit flush against the post. Drill pilot holes through the nailing block to the post.
8. When installing the guard, overlap the cut edge to the dotted line in the drawing at right.
9. Join the ends with two to four 1/4" round-head stove bolts or use four small, pan-head sheet metal screws.

Many excellent baffles are sold at local birding stores, and include parts and instructions for easy mounting.

Sheet metal wrapped around a wooden post is also recommended. The sheet metal should extend down at least 3 feet below the bottom of the box, rather than from the ground up.

PVC Baffle

Material List:

- 4-inch thin-wall PVC at least 2 feet long
- 4-inch PVC cap
- a few screws
- a conduit hanger or a hose clamp

The baffle must be free-swinging on the pipe and must wobble when the raccoon or cat tries to climb it. The hole drilled in the top of the PVC cap should be approximately 1/8 inch larger than the pipe itself. This will also keep mice from climbing up the pole and will still allow it to wobble. An oversized hose clamp is recommended in order to give the PVC added "wobble."

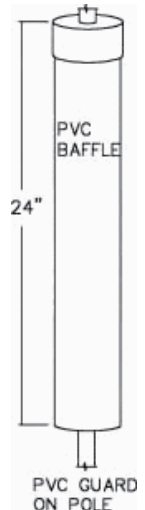

ENTRANCE HOLE GUARDS

Noel Guard

This guard is estimated to be 90% effective in keeping raccoons or cats from reaching into the box once they have gained access to it. It may also prevent woodpeckers from damaging the nestbox entrance. A rectangle of 1/2-inch hardware cloth placed around the entrance hole will make it very difficult for these predators to reach down into the nestbox. Some bluebirders recommend that the guard not be placed on the box until after the bluebirds have laid at least one egg, while others have had success leaving the guard on the box year round.

Hole Guards

This is an extra block of wood placed over the nestbox entrance, with a corresponding hole in its center. This extra 3/4-inch thickness makes it slightly more difficult for the raccoon to reach in, but unless a very deep box is used, they are still able to reach the nest. Thus, they are no longer recommended by NABS to prevent raccoon predation. However, this extra block of wood with a 1½-inch hole can be used if the original hole has been enlarged by a squirrel or woodpecker. A metal plate can also be used for this purpose, or to reduce the hole size to protect smaller birds like chickadees.



Christine Boran

Revised May 2012

The North American Bluebird Society, Inc. is a non-profit education, conservation, and research organization that promotes the recovery of bluebirds and other native cavity-nesting bird species in North America.

www.nabluebirdsociety.org

